

THIS DOCUMENT CONTAINS DATA PROPRIETARY TO PROJECTS UNLIMITED, INC. ANY USE OR REPRODUCTION, IN ANY FORM, WITHOUT PRIOR WRITTEN PERMISSION OF PROJECTS UNLIMITED, INC. IS PROHIBITED.
 ©2005, Projects Unlimited Inc.

SPECIFICATIONS

PARAMETERS	VALUES	UNITS
RATED VOLTAGE (SQUARE WAVE)	5	Vp-p
OPERATING VOLTAGE RANGE	4 ~ 6	Vp-p
RATED CURRENT (MAX)	80	mA
COIL RESISTANCE	30±5	OHM
MINIMUM SPL @ 10 CM	85	dBA
RESONANT FREQUENCY	2731±200	Hz
OPERATING TEMPERATURE	-40 ~ +85	°C
STORAGE TEMPERATURE	-50 ~ +95	°C
HOUSING MATERIAL	LCP	-
TERMINAL MATERIAL	Sn PLATED BRASS	-
WEIGHT	0.6	grams

REVISIONS			
LTR	DESCRIPTION	DATE	APPROVED
-	RELEASED FROM ENGINEERING	3/29/07	

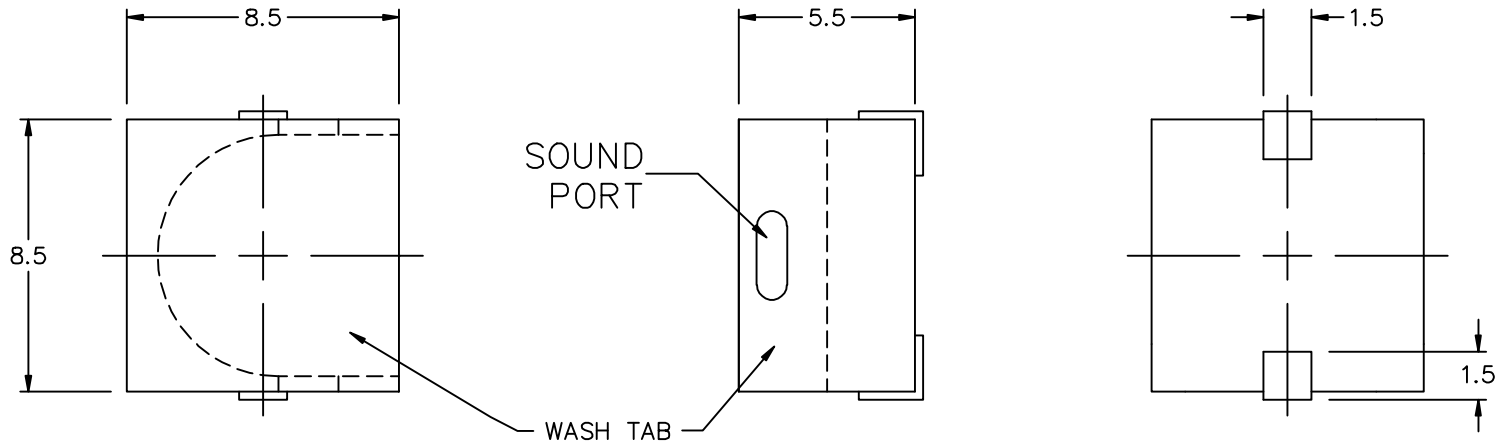

NOTES:

1. ALL DIMENSIONS ARE IN MILLIMETERS.
2. SPECIFICATION SUBJECT TO CHANGE OR WITHDRAWAL WITHOUT NOTICE.
3. THIS PART IS RoHS 2002/95/EC COMPLIANT.

FILE NAME
 SMT-0827-SW-5V-R.DWG

UNLESS OTHERWISE SPECIFIED:
 DIMENSIONS ARE IN MILLIMETERS, TOLERANCES ARE ±0.5 AND ANGLES ARE ±3°.

APPROVALS	DATE
DRAWN J.D.	3/07
CHECKED D.F.	4/07
APPROVED R.W.	4/07



TRANSDUCER (ELECTRO-MECH)

SIZE A DRAWING NO. SMT-0827-SW-5V-R

DO NOT SCALE DRAWING

SCALE: N.T.S.

SHEET 1 OF 1